

# Leonardo System

The first electrospindle for ATC  
*Il primo elettromandrino per cambio utensile automatico*



Completely integrated  
with the machine tool

*Completamente integrato  
alla macchina utensile*



Adjustable speed  
up to 60.000RPM

*Velocità fino a  
60.000 RPM regolabile*



Can be installed  
on each machine

*Installabile su ogni  
tipo di macchina*



NEW

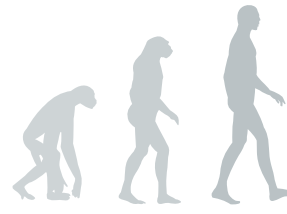

# Leonardo System

The evolution of the species

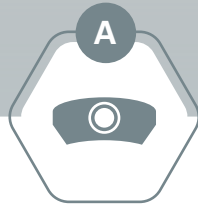
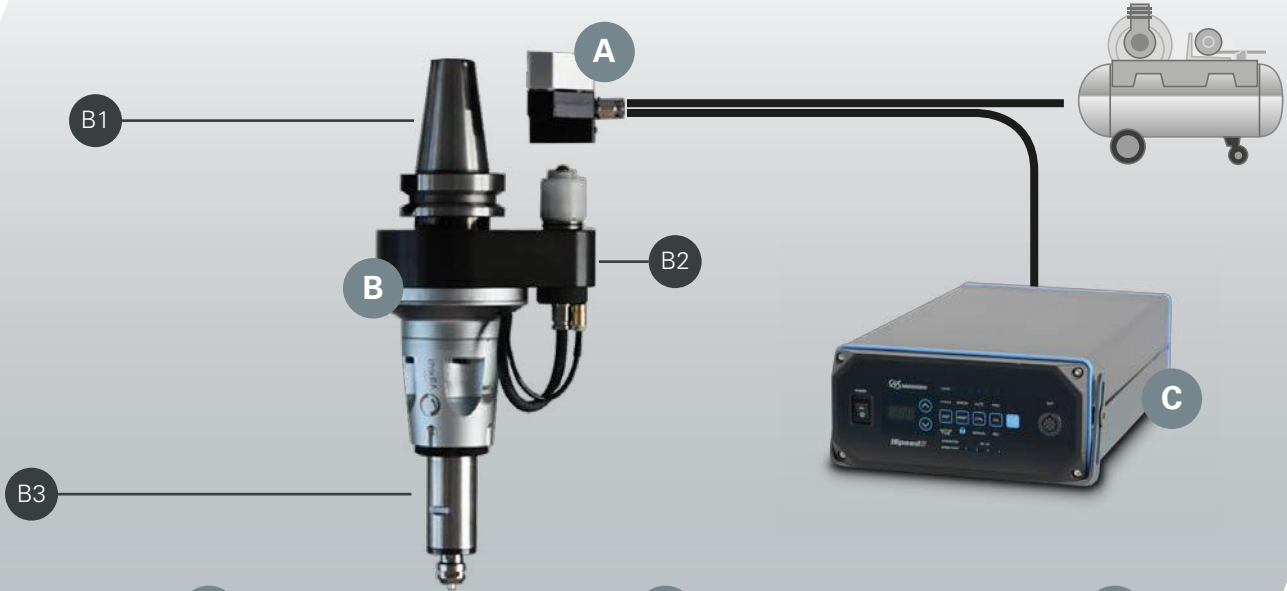

Customized stop block for each machine with 10mt. cable

*Stop Block studiato e realizzato ad Hoc con cavo lungo 10 mt.*

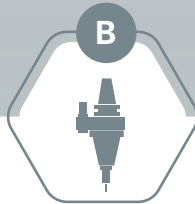

- 1) Different shanks available
- 2) Indexing pin with protected electric contacts
- 3) Axial electrospindle Leonardo head

*1) Cono intercambiabile  
2) Perno con contatti elettrici protetti  
3) Testa assiale Leonardo*

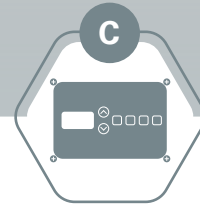

Ispeed5 controller unit with adjustable speed

*Centalina NAKANISHI Ispeed 5 con regolazione di giri*



**350 Watt**

Max power  
*Potenza massima*



up to / fino a  
**60.000**

RPM  
*Velocità g/min*



up to / fino a  
**6 mm**

Collet  
*Pinza*



**4,8 kg**

Weight  
*Peso*



**1 μ**

Spindle accuracy  
*Precisione*



**Alberti**  
www.albertiumberto.com  
info@albertiumberto.com

Via Gorizia, 37  
21047 Saronno (VA) Italy  
Tel. +39 0296.703.586  
Fax +39 0296.703.620