

MOLTIPLICATORE SPEEDER

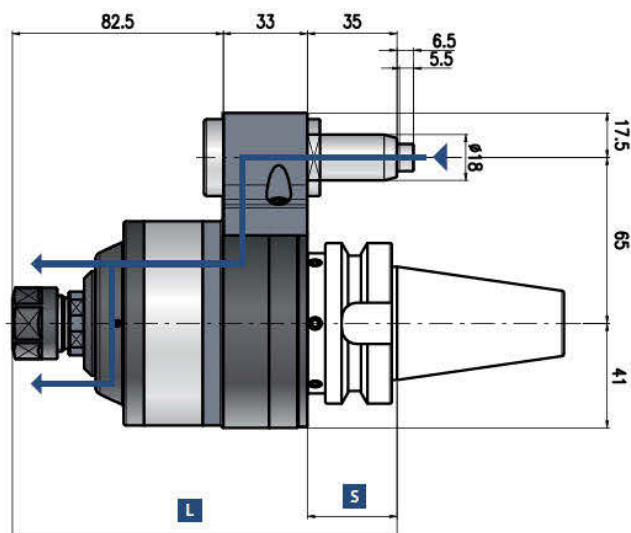

Corpo principale con sistema di raffreddamento ad aria
Main body with air-water cooling system

Fori per raffreddamento ad aria o acqua
Bores for air-water cooling system



Entrata aria acqua
Air-coolant input

Pinza ER 16
ER 16 collet

Gruppo perno modulare
Interchangeable pitchdimension



Ratio
Rapporto
1:5



RPM
Velocità
25.000 min⁻¹



Max. axial load
Max. carico assiale
60 N



Torque
Momento torcente
4 Nm



Weight
Peso
4 kg



Collet
Pinza
ER-16 \varnothing 1/10 mm

*** STANDARD EQUIPMENT INCLUDES:**



Shank/Cono	DIN-69871	CAT	MAS-BT	HSK		CAPTO		KM
Size/Grandezza	40-50		40-50	63-80	100	C6	C8	63
I	80-100		80-100	80-100	80-100	80-100	80-100	80-100
S	35		41	42	45	38	40	40
L	150.5		156.5	157.5	160.5	153.5	155.5	155.5

*optional

Non interchangeable input drive shank/ Coni di attacco non intercambiabili