



Alberti®

**TURBODRILL / TURBOFLEX
ANGLE HEADS**



**TURBODRILL /
TURBOFLEX**

**INSTRUCTION
BOOK**

TABLE OF CONTENTS

	Page
Safety Recommendations.....	1
Tool Run-in.....	2
Determining the Retaining Block Thickness.....	2
Mounting the Retaining Block.....	4
Retaining Block Mounting Errors.....	5
Radial Positioning of Angle Heads Around the Z Axis.....	6
Re-setting the Graduation Ring (if applicable).....	6
Air / Oil Regulator Installation.....	7
Air / Oil Regulator Operation.....	7
Air / Oil Regulator Picture Diagram.....	8
Troubleshooting.....	9
IC-300 / KC-300 Cutting Tool & Collet Instructions.....	10
RA-100 / RA-200 Cutting Tool & Collet Instructions.....	11
Turbodrill (30 Taper) / NSK Tooling Chart.....	12
Turboflex / NSK Tooling Chart.....	14
Collet Chart.....	15
Warranty.....	17
Parts and Service.....	17



Alberti[®]

Via Gorizia, 37 - 21047 Saronno (VA) - Italy
Tel. + 39 02 96 703 586 - Fax + 39 02 96 703 620
info@albertiumberto.it

SAFETY RECOMMENDATIONS

- Do not touch or hold anything near the head when it is running or rotating in any manner.
- When the angle head is mounted in the machine spindle or tool magazine, be sure it is not hot.
- When the head is to be used, ensure the input taper is correctly mated to the machine spindle, the arrester arm and block are engaged properly, and that the cutting tool is clamped tightly before activating the air circuit to start the spindle rotating.
- Make sure the cutting tool is designed to run in the same direction as the NSK air motor (R = Right and L = Left).
- Use caution during set-up of the head as personal injury may occur if dropped or mishandled.

AUTOMATIC TOOL CHANGER

- Check the Automatic Tool Changer (ATC) speed and manually check loading and unloading of the head into the machine spindle prior to running in automatic cycle.
- Routinely check the stopper block to be sure it is clean and free of chips.

NSK CARTRIDGE INFORMATION

- The threaded input of the cartridge is not qualified to the output. To ensure accurate positioning, install the NSK cartridge into the head, insert the ground mandrel in the collet and indicate to confirm / adjust the position.
- The NSK cartridges are not designed to withstand high axial and radial thrust.
- A weekly visual inspection and cleaning of the head is recommended.
- Be sure to check the oil level on the oil lubricator periodically.
- Always use cutting tools with precision ground shanks to ensure proper tightening and minimal tool runout.
- For extended reach machining, a CN-01 extension spacer may be used.



Alberti[®]

Via Gorizia, 37 - 21047 Saronno (VA) - Italy
Tel. + 39 02 96 703 586 - Fax + 39 02 96 703 620
info@albertiumberto.it

TOOL RUN-IN

For new heads or units that have not been used for over (1) month, the motor speed should be increased gradually. Increase the air pressure slowly using the pressure adjustment knob (refer to drawing on page 8), over a period of 15-20 minutes, until the unit is at maximum operating speed.

DETERMINING THE RETAINING BLOCK THICKNESS

Use the following procedure to locate the retaining block so that the axial stroke of the release pin is exactly $5^{+0.5\text{ mm}}$.

1. Mount the angle head in the machine tool spindle and measure dimension **X**. (Fig 1a)
2. Remove the angle head from the machine tool spindle and slip the retaining block on the arrester pin.
3. Measure dimension **W** without pressing the release pin. (Fig 1b)
- 4^a. If dimension **W** is less than dimension **X**, prepare a shim with thickness as below:
$$S = (X - W + 5\text{mm})^{+0.5\text{mm}}$$
- 4^b. If dimension **W** is greater than dimension **X**, machine the thickness of the retaining block as below:
$$W = (X + 5\text{mm})^{+0.5\text{mm}}$$
5. Make sure the spring loaded release pin is depressed $5\text{mm} \pm 0.5\text{ mm}$ when the angle head is mounted in the machine tool spindle to allow free rotation of the angle head spindle.
6. Make sure the bottom of the arrester pin does not come in contact with the bottom of the retaining block. (Fig 2)



Alberti

Via Gorizia, 37 - 21047 Saronno (VA) - Italy
Tel. + 39 02 96 703 586 - Fax + 39 02 96 703 620
info@albertiumberto.it

DETERMINING THE RETAINING BLOCK THICKNESS

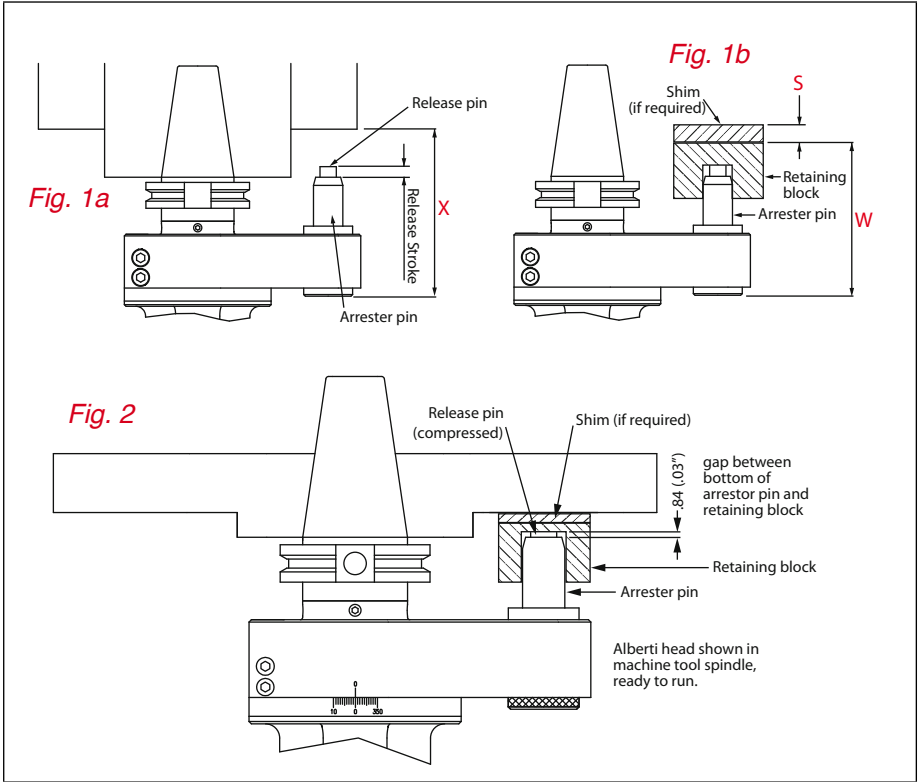

Alberti

Via Gorizia, 37 - 21047 Saronno (VA) - Italy
 Tel. + 39 02 96 703 586 - Fax + 39 02 96 703 620
 info@albertiumberto.it

MOUNTING RETAINING BLOCK • ORIENTATION OF ARBOR

To locate the retaining block at the correct distance from the spindle center line and to assure the correct orientation of the arbor with reference to the arrester pin, use the following procedure:

1. Secure the retaining block by slightly tightening the mounting screws.
2. Loosen set screws **06** one turn and fit the head into the machine spindle (make sure that the arrester pin slips in easily).
3. Fully tighten the mounting screws of the retaining block.
4. Remove and carefully clean set screws **06**.
5. Check whether the collet chuck is properly oriented for tool change.
6. Put a few drops of Loctite 242e or equivalent on the threads of set screws **06** then tighten set screws **06** on orientation ring **10**.
7. Unload and load the head several times with the automatic tool changer to check for correct operation.
8. Dowel the retaining block to the machine tool to prevent any shifting.

ATTENTION: During the first automatic tool change, make sure that the angle head does not interfere with other components of the system.

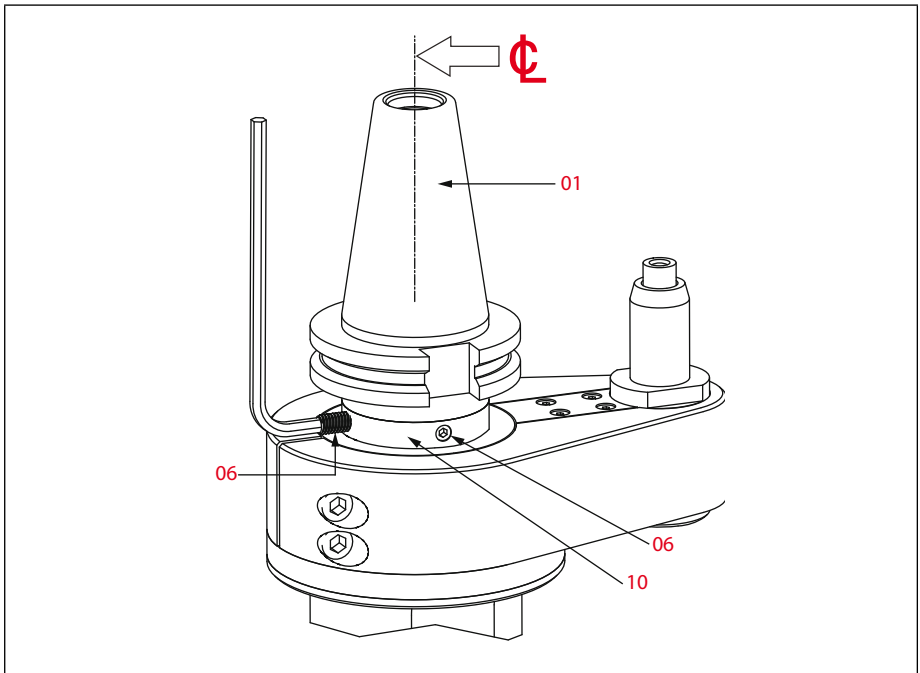

RETAINING BLOCK MOUNTING ERRORS

If the distance from the machine tool spindle centerline and the centerline of the retaining block bushing is not correct, the arrester pin on the angle head will not seat properly in the retaining block bushing. This will result in the conditions shown below, causing damage to the angle head bearings.

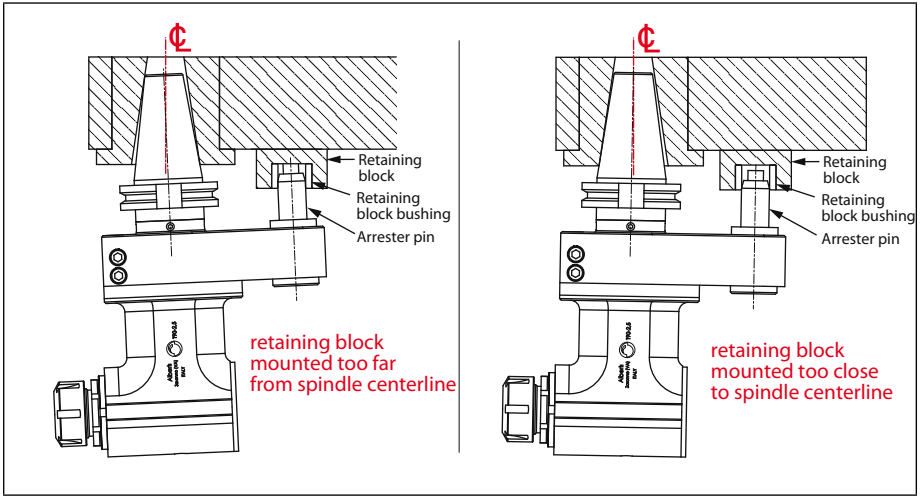

If the release pin (in the arrester pin) is completely compressed against the bottom of the retaining block, the shank of the angle head will not seat properly in the machine tool spindle, causing damage to the angle head bearings. The .84mm/.03" gap between the bottom of the arrester pin and the retaining block must be met in order for the angle head shank to seat properly in the machine tool spindle (see page 3).

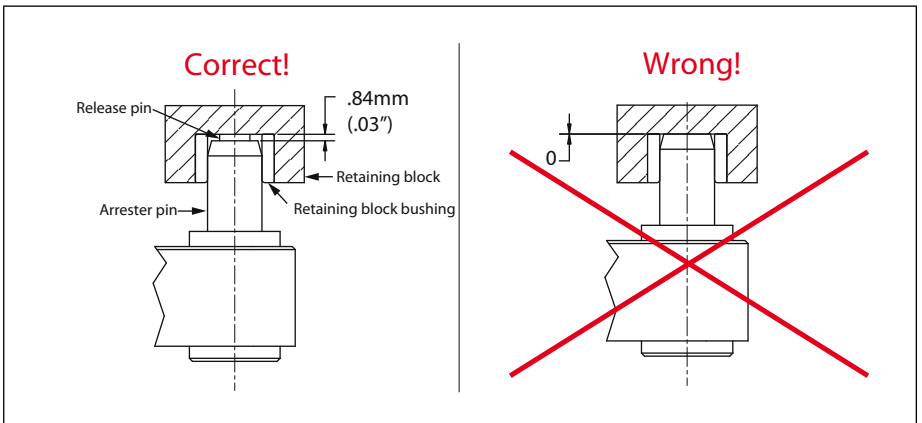

Alberti

Via Gorizia, 37 - 21047 Saronno (VA) - Italy
Tel. + 39 02 96 703 586 - Fax + 39 02 96 703 620
info@albertiumberto.it

RADIAL POSITIONING OF TURBOFLEX ANGLE HEADS

Applies to: RA-200, RA-100, RA-271E, RA-151E, & RAX-271E NSK Cartridges.

To position the angle head body radially around the Z axis of the machine tool, use the following procedure:

1. Mount the angle head on the machine.
2. Loosen screws **08**.
3. Rotate angle head body **30** to the required position.
3. Clamp a ground mandrel in the collet of the NSK output and use a dial gauge with a flat point to check for precise position.
5. Tighten screws **08**. Suggested screw torque 8-10 Nm (5.9-7.4 ft.lbs.). Do not use an extension for the Allen wrench.

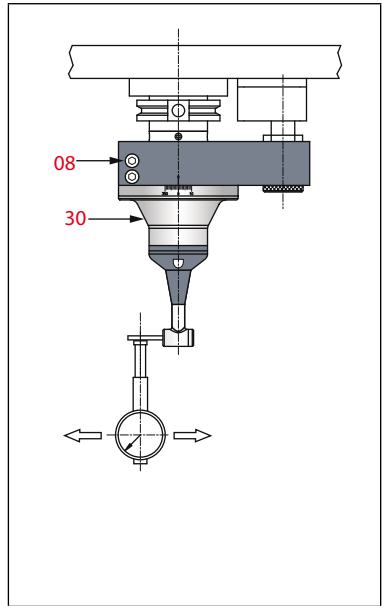

RE-SETTING THE GRADUATION RING (IF APPLICABLE)

Applies to: RA-200, RA-100, RA-271E, RA-151E, & RAX-271E NSK Cartridges.

When the head is correctly oriented and positioned, graduated ring **12** can be reset. Loosen screw **13** and rotate the ring until the zero coincides with the reference notch in the indexing flange. Re-tighten screw **13**.

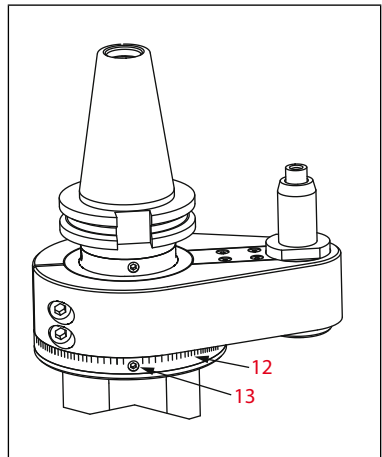

AIR / OIL REGULATOR (#AL-0304) INSTALLATION

Refer to picture diagram on page 8 for these instruction.

- Mount this unit on the machine tool, in a convenient location with easy access for servicing (maintaining the proper oil level and draining of the water).
- Fill oil reservoir using ISO-VG15 (paraffin based) oil or equivalent.
- Connect the air input line to the input side of the unit. (Be sure shut-off valve is "OFF").

NOTE: It is recommended that a Quick Disconnect be used for the input air line!

- Connect the air output line to the stopper block (1/8" NPT) or thru spindle circuit. (Stopper block set-up is most common).
- Adjust the air pressure using the air pressure regulator adjustment knob. Recommended pressure is 58 - 87 psi (0.4 - 0.6 MPa).
- Open the shut-off valve and adjust the oil drip rate using the oil lubricator adjustment screw to 1 drop/sec. (This is a rough setting and will need to be fine-tuned once the head is connected).

AIR / OIL REGULATOR (#AL-0304) OPERATION

Refer to picture diagram on page 8 for these instruction.

- **Oil Volume:** Check the oil reservoir at least once a week. Use caution to avoid under and over filling of the reservoir as it can cause the oil delivery rate to vary.

CAUTION: Be sure to disconnect the air input line and check for zero pressure at the gage, prior to opening the oil filler cap!

- **Water in the Air Filter:** Drain the water from the moisture reservoir by unscrewing the black cap at the bottom of the reservoir bowl.
- **Adjusting the Oil Drip Rate:** Run the head at the desired air pressure/RPM and adjust the oil drip rate to the recommended amount by turning the lubricator adjustment screw. Turn the CCW to increase the drip rate and CW to decrease the drip rate.
- **Remove Oil & Moisture Regularly:** Remove and replace the oil in the reservoir once a month to ensure a pure lubricant for the motor. Moisture may collect and mix with the oil in the reservoir causing premature damage to the motor. The easiest method to remove the oil and clean the bowl is to remove it from the reservoir. Depress the release button in the downward direction and rotate the bowl for removal.
- **Oil Grade:** ISO VG-15 (paraffin based oil) is recommended.



Alberti[®]

Via Gorizia, 37 - 21047 Saronno (VA) - Italy
Tel. + 39 02 96 703 586 - Fax + 39 02 96 703 620
info@albertiumberto.it

AIR / OIL LUBRICATOR DIAGRAM

AL-0304 Air / Oil Lubricator w/ Shut-Off Valve

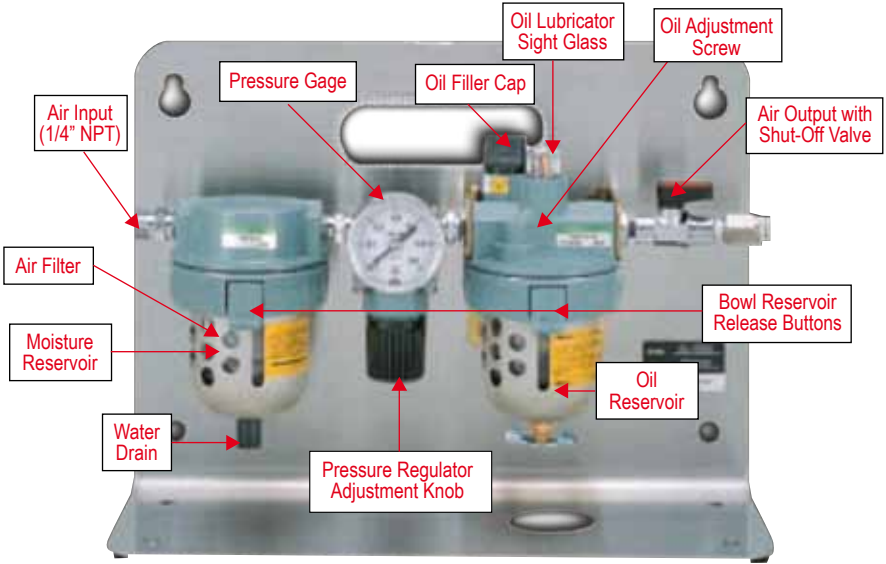

TROUBLESHOOTING

PROBLEM	PROBABLE CAUSE	SOLUTION
Low Rotation Speed	Leaking air supply	Check all connections, retighten & seal.
	Broken hose	Replace.
	Low air-flow or pressure	Check the air circuit.
	No or low oil supply	Check the oil level in the reservoir and increase the drip rate. (1 drop/sec.)
	Inclined or vibrating lubricator	Mount lubricator horizontally and in a location that is free from vibration.
	Excessive oil in the reservoir	Remove excess oil, which causes the delivery rate to vary.
	Excessive oil drip rate	Re-adjust oil drip rate to recommended amount.
	Moisture in the oil reservoir	Drain moisture from the reservoir and replace oil
	Moisture in the air filter	Drain moisture.
No Rotation	No air flow	Check the pressure gage and adjust to the recommended pressure. Check all hose connections. Check air compressor. (Power supply and air outlet).
	Damaged motor bearings	Return the head for service.



Alberti

Via Gorizia, 37 - 21047 Saronno (VA) - Italy
 Tel. + 39 02 96 703 586 - Fax + 39 02 96 703 620
 info@albertiumberto.it

MOUNTING A CUTTING TOOL • IC-300 • KC-300

Attach the collet wrench provided onto the head of the attachment. Apply light pressure to the head of the collet wrench. Place the spanner wrench on the chuck and turn it slowly counter-clockwise. The collet wrench will engage within 90° of wrench rotation. Keep turning the spanner wrench until the tool can be removed. When mounting a cutting tool, rotate the spanner wrench clockwise to tighten the tool firmly.

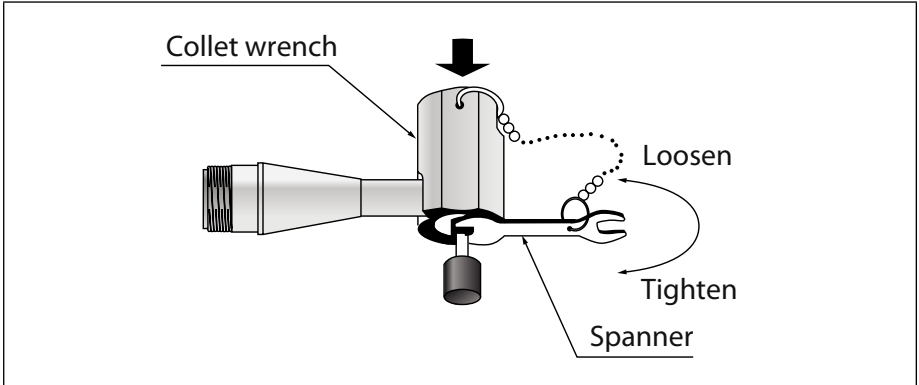

REPLACING THE COLLET CHUCK • IC-300 • KC-300

After the cutting tool is removed, rotate the collet chuck counter-clockwise with fingers until the collet chuck is disconnected. Remove the collet chuck. To replace, insert a new collet chuck and screw in a clockwise direction.

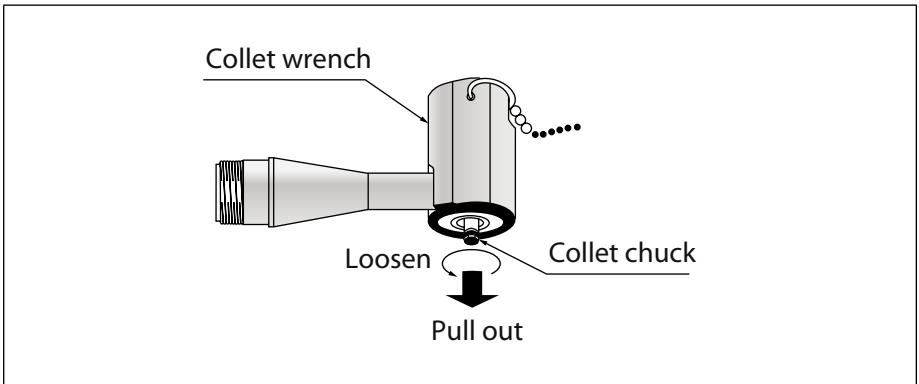

MOUNTING A CUTTING TOOL • RA-100 • RA-200

Set the provided 8mm wrench on the spindle. Place the provided 5.5mm wrench on the chuck and turn it counter-clockwise to loosen the collet and remove the cutting tool. Insert the new tool and tighten the collet by turning clockwise.

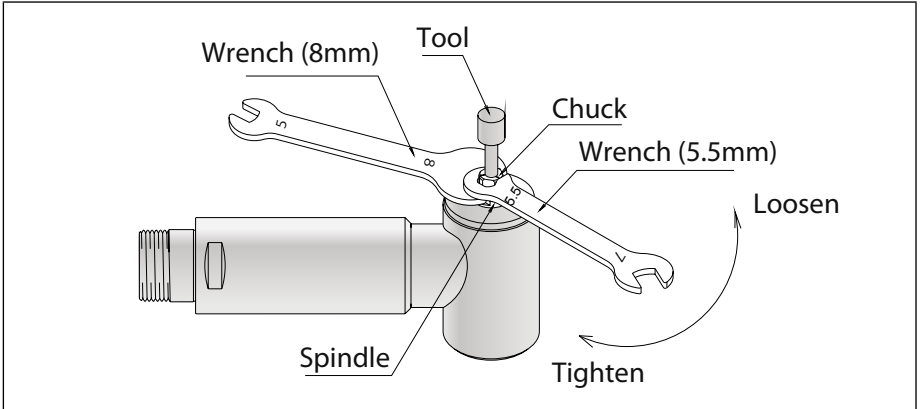

REPLACING THE COLLET CHUCK • RA-100 • RA-200

Remove the cutting tool using above instructions. Use the provided wrench to hold the spindle in place and remove the collet by turning it counter-clockwise by hand.

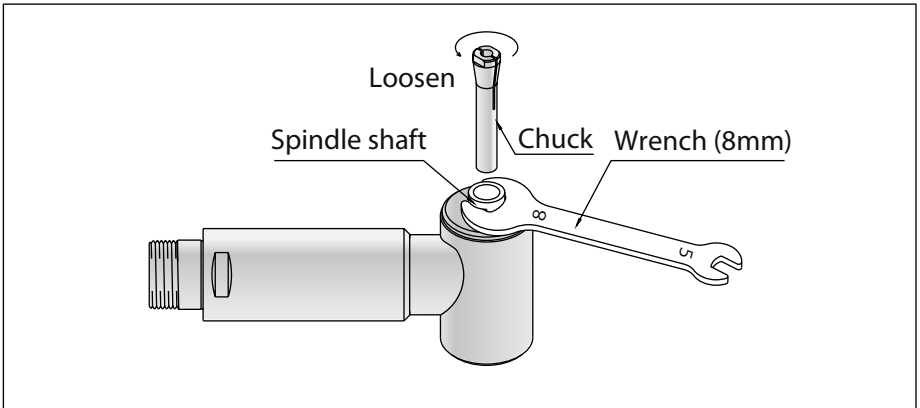

Alberti

Via Gorizia, 37 - 21047 Saronno (VA) - Italy
Tel. + 39 02 96 703 586 - Fax + 39 02 96 703 620
info@albertiumberto.it

TURBODRILL (30 TAPER) / NSK TOOLING CHART

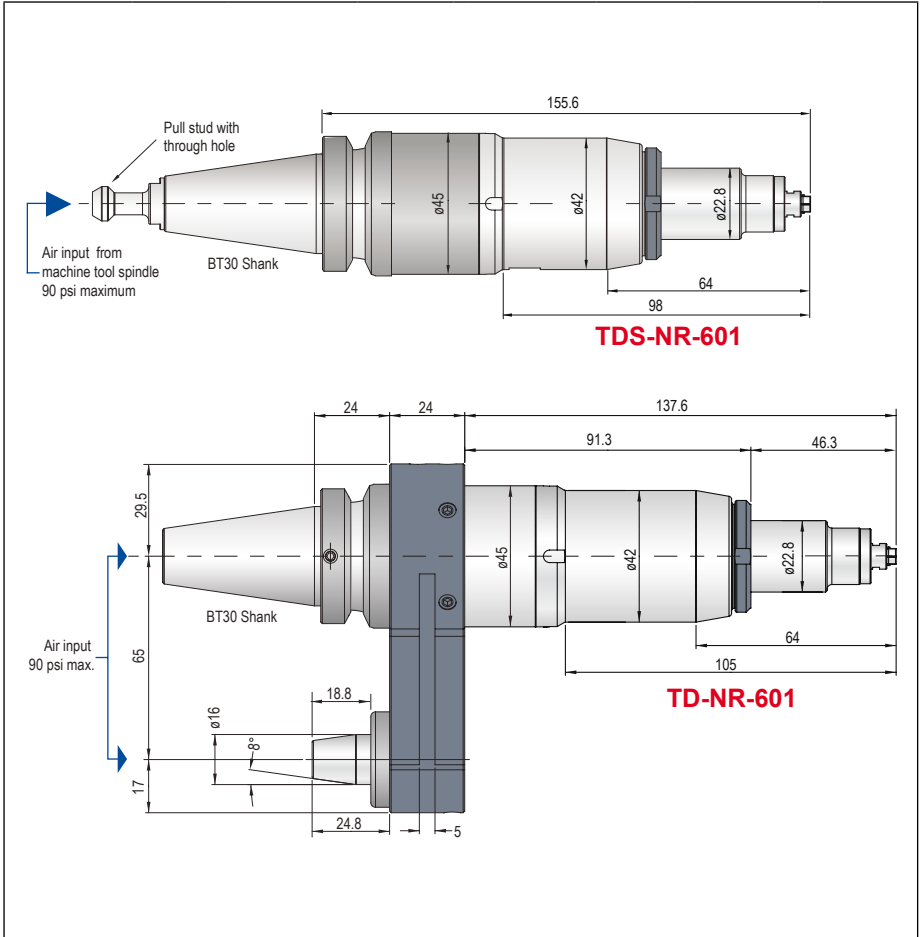

NSK TOOL TECHNICAL INFORMATION

TECHNICAL DATA • TDS-NR-601			
Tool RPM Max.	60,000	Reduction Ratio	1/1
NSK Output RPM	60,000	Air Pressure	90 psi max.
Air Motor	AM-600	Air Consumption	5.65 cfm
NSK Output Tool	NR-601	Weight	2.7 lbs.
Power	0.10 HP	Collet	CHM

TECHNICAL DATA • TD-NR-601			
Tool RPM Max.	60,000	Reduction Ratio	1/1
NSK Output RPM	60,000	Air Pressure	90 psi max.
Air Motor	AM-600	Air Consumption	5.65 cfm
NSK Output Tool	NR-601	Weight	4.1 lbs.
Power	0.10 HP	Collet	CHM



TURBODRILL (30 TAPER) / NSK TOOLING CHART

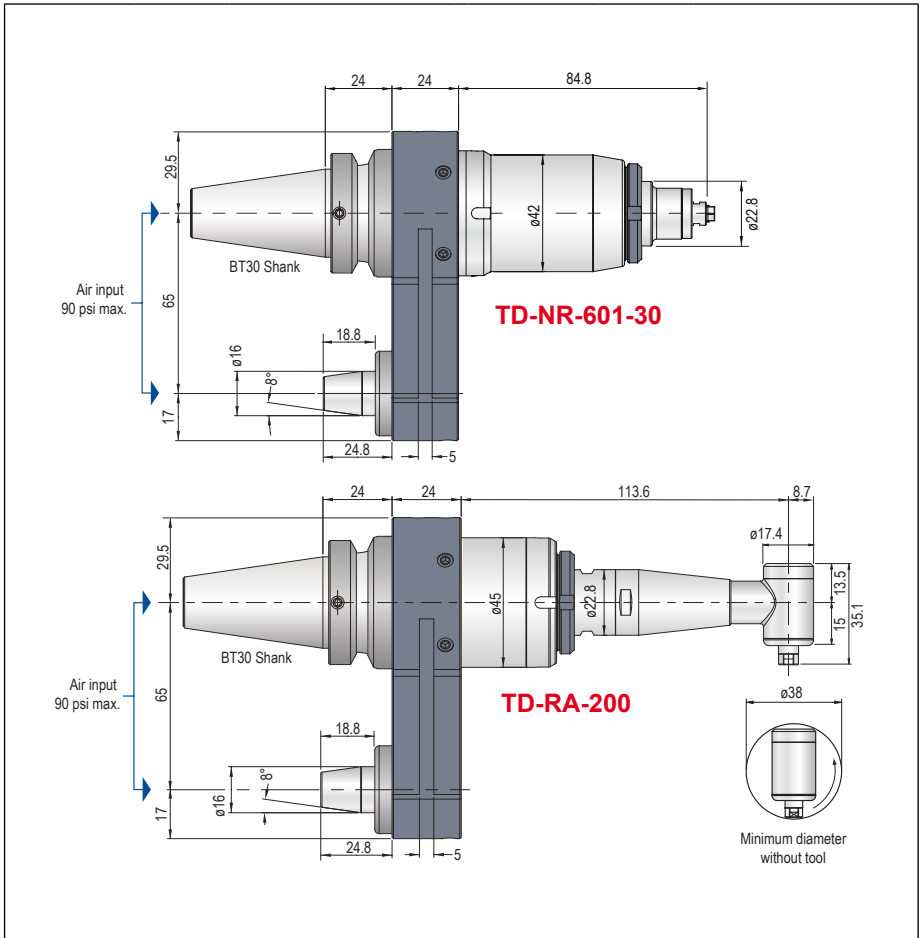

NSK TOOL TECHNICAL INFORMATION

TECHNICAL DATA • TD-NR-601-30			
Tool RPM Max.	30,000	Reduction Ratio	1/1
NSK Output RPM	30,000	Air Pressure	90 psi max.
Air Motor	AM-310	Air Consumption	7.98 cfm
NSK Output Tool	NR-601	Weight	4.1 lbs.
Power	0.14 HP	Collet	CHM

TECHNICAL DATA • TD-RA-200			
Tool RPM Max.	30,000	Reduction Ratio	1/1.5
NSK Output RPM	20,000	Air Pressure	90 psi max.
Air Motor	AM-310	Air Consumption	7.98 cfm
NSK Output Tool	RA-200	Weight	4.1 lbs.
Power	0.14 HP	Collet	CHS



Alberti

Via Gorizia, 37 - 21047 Saronno (VA) - Italy
 Tel. + 39 02 96 703 586 - Fax + 39 02 96 703 620
 info@albertiumberto.it

TURBOFLEX / NSK TOOLING CHART

High Speed Tools up to 60,000 RPM

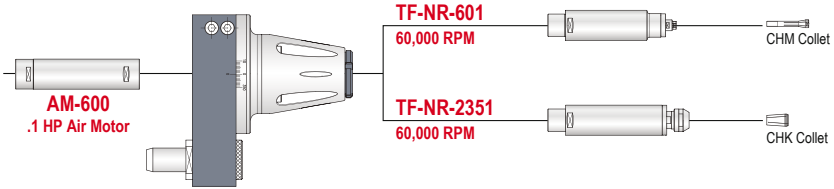

High Speed Tools up to 30,000 RPM

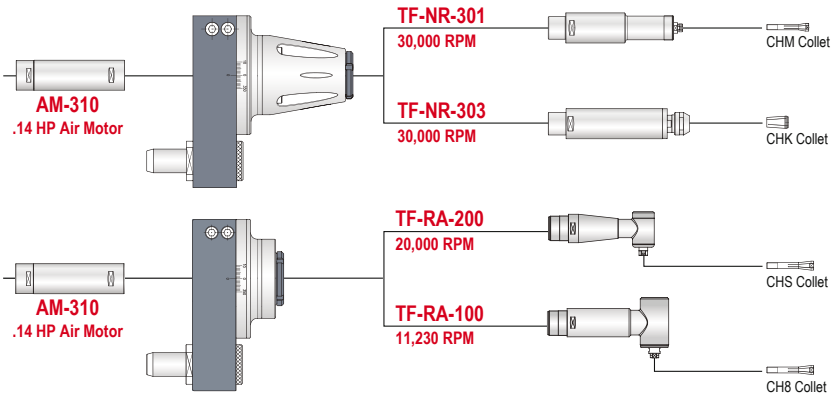

High Speed Tools up to 18,000 RPM

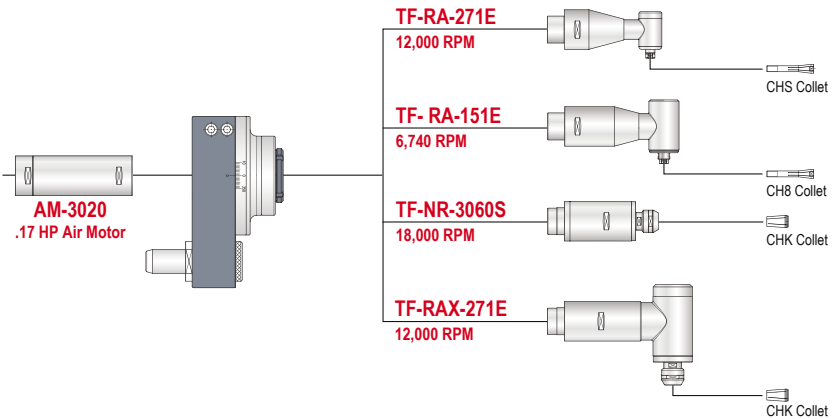

Via Gorizia, 37 - 21047 Saronno (VA) - Italy
Tel. + 39 02 96 703 586 - Fax + 39 02 96 703 620
info@albertiumberto.it

COLLETS

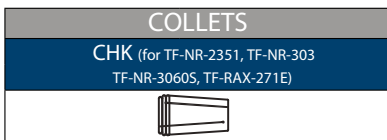
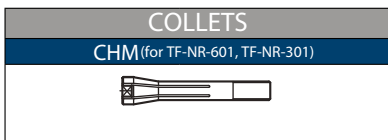
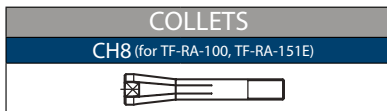
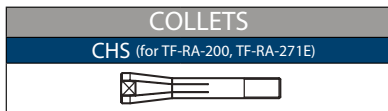

AIR FILTERING UNIT

OPTIONAL AIR LINE KIT



OPTIONAL

30.000 RPM MOTOR CONVERSION KIT

Type 1



Type 2



WARRANTY

All product lines sold by Alberti carry a manufacturers guarantee of one year from the date of purchase. This warranty covers parts and labor due to defects in materials and workmanship. This warranty does not apply to any products that have been subject to misuse, neglect or accident. Products repaired by Alberti will carry a 6 mounths warranty.

PARTS AND SERVICE

Please contact



Alberti[®]

Via Gorizia, 37 - 21047 Saronno (VA) - Italy
Tel. + 39 02 96 703 586 - Fax + 39 02 96 703 620
info@albertiumberto.it



Via Gorizia 37
21047 Saronno (VA)
Italy
Tel. +39 02 96 703 586
Fax +39 02 96 703 620
info@albertiumberto.it

