

# La nuova era del Quick Change

*The new era of Quick Change*

VELOCE

*Quick*

FACILE

*Easy*

PRECISO

*Accurate*

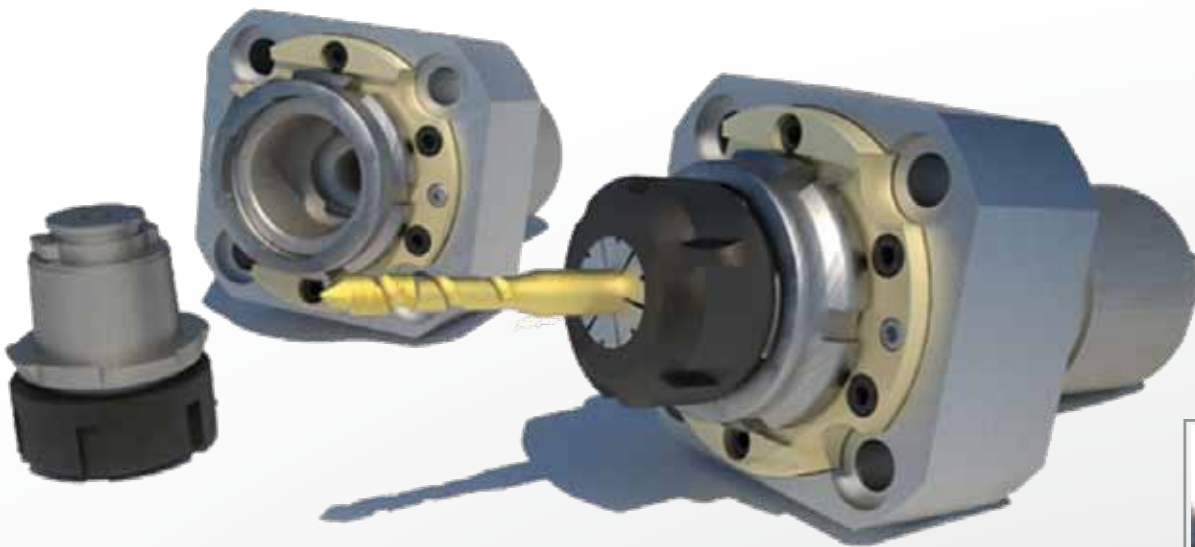

 **SmartChange**

Triplo contatto per una miglior precisione  
Triple contact for a higher precision

Design compatto  
Compact design

Presettaggio fuori macchina  
Outside presetting

Maggior flessibilità  
Increased flexibility

Minor costi e tempi di  
attrezzaggio macchina  
Lower costs and reduced  
set up time



## SmartChange

### Sistema triplo contatto / Triple contact system

#### Superfici di appoggio / Contact surfaces

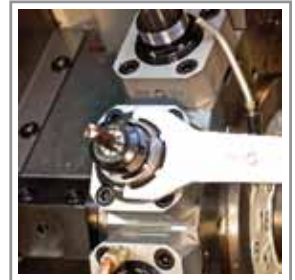
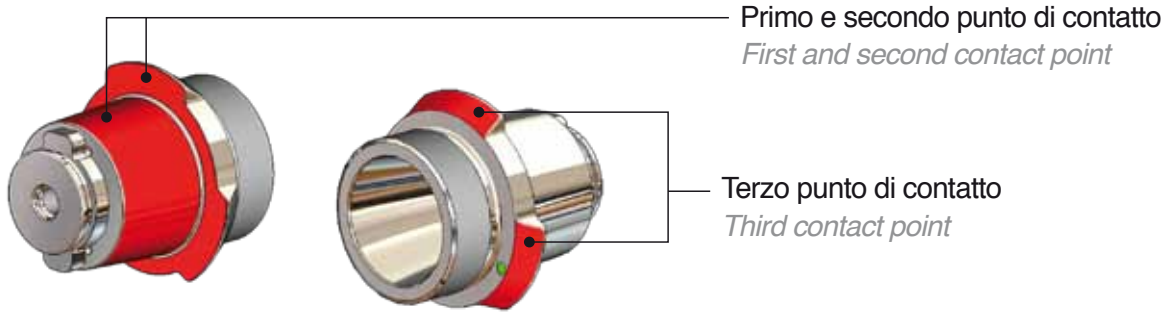

#### Tabella dati tecnici / Technical data

Tempo massimo di sostituzione cartucce <i>Time to change front end</i>	20"	Precisione con barra inserita nel mandrino <i>Accuracy with gauge bar inserted in the collet chuck</i>	
Ripetibilità / <i>Repeatability</i>	0,003 mm	a 40 mm = 0,008 mm	at 40 mm = 0,008mm
		a 120 mm = 0,01 mm	at 120 mm = 0,01mm

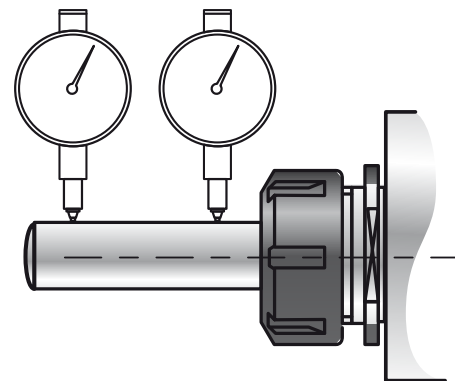
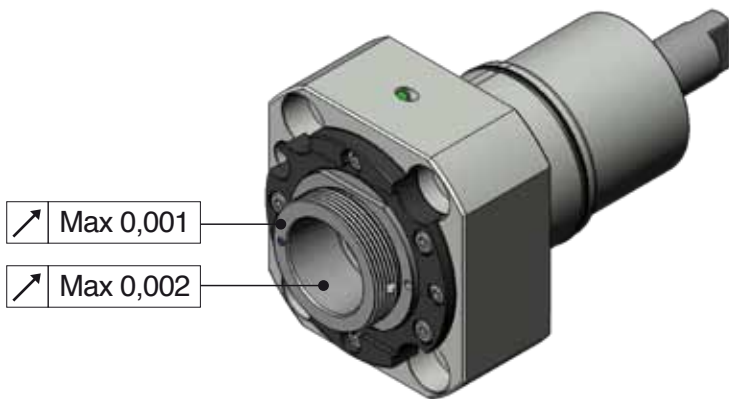

#### Come funziona / How it works

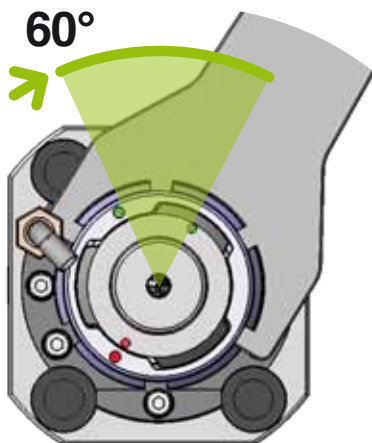

● Bloccaggio / Clamping

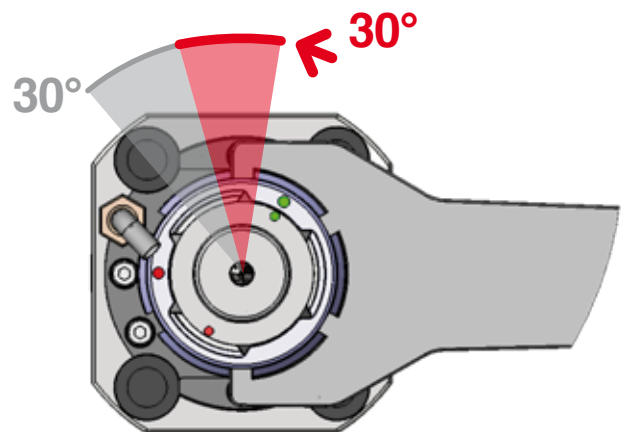

● Sbloccaggio / Unclamping

● Estrazione / Pull out



## SmartChange

Disponibile anche con adduzione refrigerante interna max 70 bar.  
Available also with internal coolant max 70 bar.

### CARTUCCE / adapters

grandezza max disponibile  
max dimension available

ER20 / ER25 / ER32

Weldon Ø 10 / 12 / 16 mm

P. fresa - 13 / 16 / 22 mm  
shell mill holder - 13 / 16 / 22 mm



### Nakamura

TW10 / SC150 / SC250 / WT150 / WT250 / WTW150 / WTS150 / NTM3

SUPER NTJ / NTJX

WT100 / NTY 3 / WY100

### Mori Seiki

NL 1500 - 2000 - 2500 - 3000 ER 32

NZ 1500-2000 / NT 3000 / NL 1500-2000 20 Staz / DURATURN 2050MC / 2550MC

### Okuma

LB2000EX / LB3000EX / (VDI 40) LR15M / LB15M / LB300 / LR25M / LB25M

LU25M / LB400 / LT25MY / LT400 / LTV400M

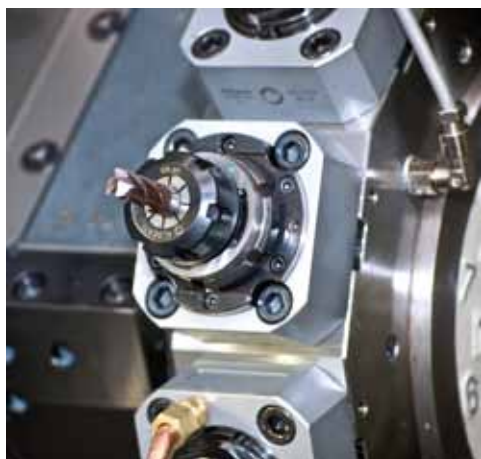

## SmartChange

### Presettaggio fuori macchina / *Outside presetting*

Grazie al nostro sistema è possibile con un adattatore universale presetare gli utensili fuori macchina aumentando così la produttività e riducendo costi e tempi di attrezzaggio.

*This system allows to pre-set all the tools outside the machine thanks to a universal adapter for all presetters.*

*This speeds up the tool change and as a consequence the production cycle.*

Adattatore per pre-set ISO 50 - Smart Change  
Tool pot adapters ISO 50 - Smart Change

