

Leonardo System

The first electrospindle for ATC
Il primo elettromandrino per cambio utensile automatico

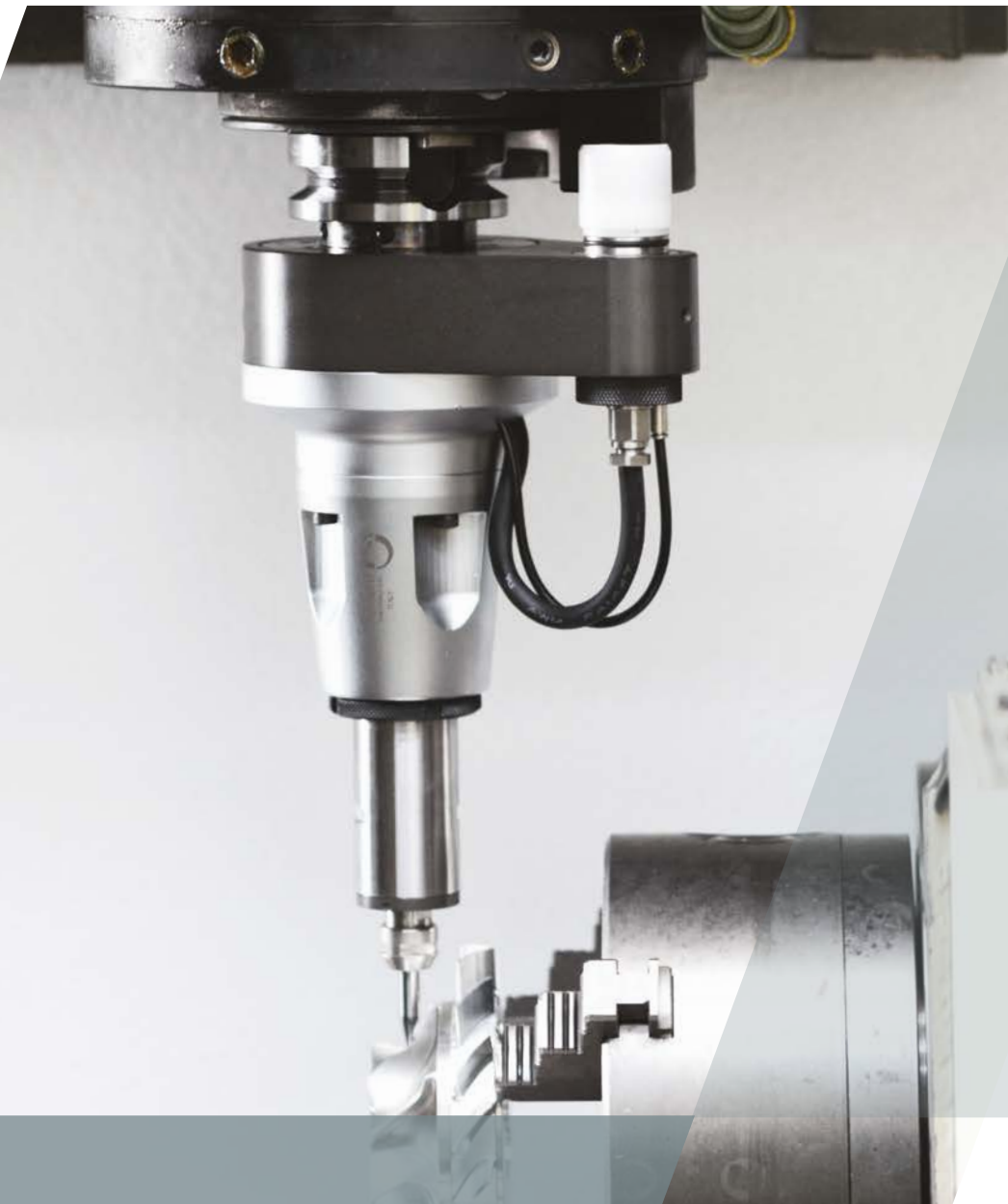

Completely integrated
with the machine tool

*Completamente integrato
alla macchina utensile*



Adjustable speed
up to 60.000RPM

*Velocità fino a
60.000 RPM regolabile*



Can be installed
on each machine

*Installabile su ogni
tipo di macchina*



NEW

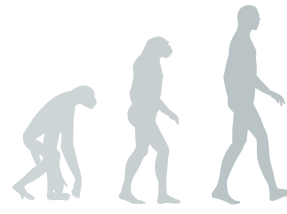

Leonardo System

The evolution of the species

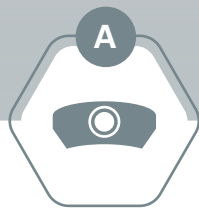
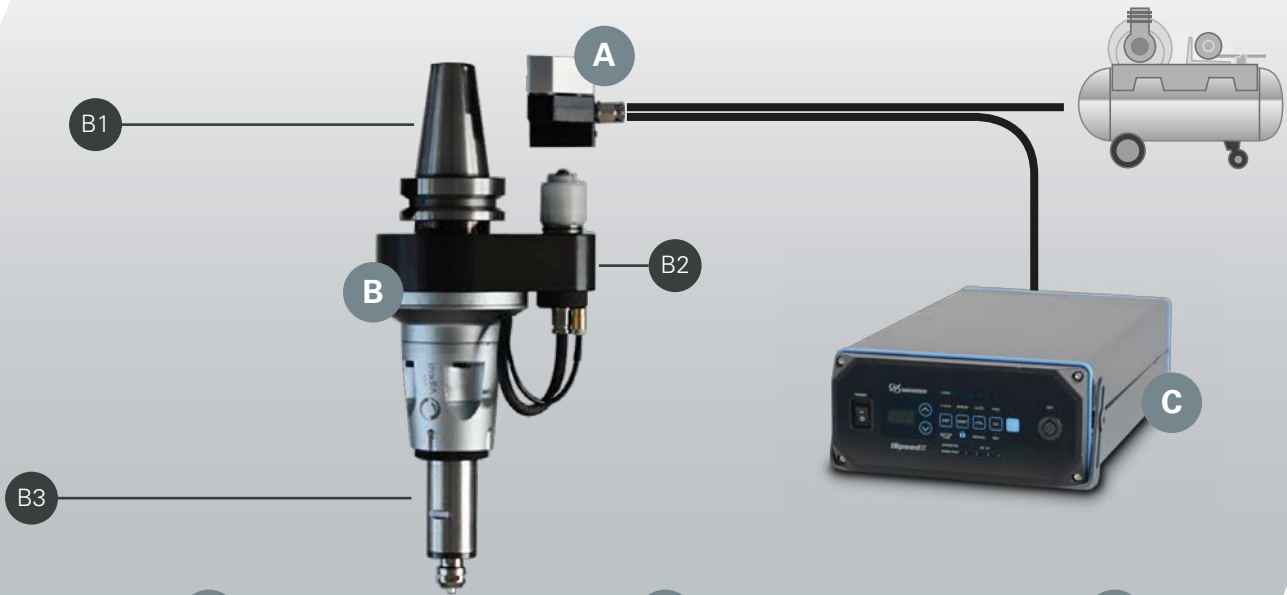

Customized stop block for each machine with 10mt. cable

Stop Block studiato e realizzato ad Hoc con cavo lungo 10 mt.

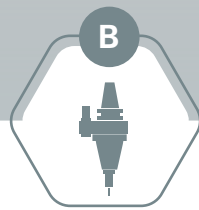

- 1) Different shanks available
- 2) Indexing pin with protected electric contacts
- 3) Axial electrospindle Leonardo head

*1) Cono intercambiabile
2) Perno con contatti elettrici protetti
3) Testa assiale Leonardo*

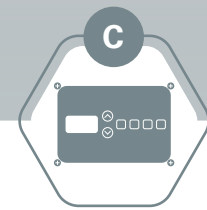

Ispeed5 controller unit with adjustable speed

Centalina NAKANISHI Ispeed 5 con regolazione di giri



350 Watt

Max power
Potenza massima



up to / fino a
60.000

RPM
Velocità g/min



up to / fino a
6 mm

Collet
Pinza



4,8 kg

Weight
Peso



1 μ

Spindle accuracy
Precisione



Alberti
www.albertiumbero.com
info@albertiumbero.com

Via Gorizia, 37
21047 Saronno (VA) Italy
Tel. +39 0296.703.586
Fax +39 0296.703.620